

SIMULATION OF A BI-DIRECTIONAL DC-DC CONVERTER FOR PV APPLICATIONS

Dr.R.Seyezhai and M.UmaMaheswari

Associate Professor, Department of EEE, SSN College of Engineering, Chennai.

ABSTRACT

Bi-directional DC-DC converter allows transfer of power between two dc sources, in either direction. In this paper the proposed converter is a combination of two topologies, namely half bridge on the primary and a current fed push pull on the secondary side of a high frequency isolation transformer. Thus providing the desired bi- directional flow of power for battery charging and discharging using only one transformer, as opposed to two in conventional schemes. In this paper, the operation of the converter in charging and discharging modes in open and closed loop is discussed and the simulations results are verified. The circuit configuration has been simulated using PSPICE. Comparisons of the simulation results for open loop and closed loop control system is performed. The results show that closed loop control system reduces distortion and the dynamic response of the converter is improved.

KEYWORDS

Bi-directional DC-DC converter, forward and reverse charging modes, PSPICE and closed loop

1. INTRODUCTION

Choppers are widely used to obtain a variable DC output voltage from a constant DC voltage. It can be used for step-up and step down operation. Implementation of bidirectional converters using resonant, soft switching and hard switching PWM are reported in the literature[1]. But, these topologies may often lead to an increase in component ratings, circuit complexity and conduction losses in resonant mode implementations, high output current ripple and loss of soft switching at light loads for soft-switched circuits, and lack of galvanic isolation in integrated topologies[2]. But this paper presents a bidirectional dc–dc converter topology for battery charger/discharger. In the proposed topology, the bi-directional power flow is achieved by two topologies namely half bridge and current fed push-pull topology. The primary side of the converter is a half bridge and is connected to the dc mains. The secondary side, connected to the battery, forms a current-fed push-pull. The benefits of a current fed push-pull converter are reduced switching losses in push-pull stage and the output rectification can be easily optimized. Simulation studies of the proposed converter is carried out using PSPICE. The proposed converter topology with feedback has been presented and simulated using PSPICE. The converter demonstrates high efficiency (86.6% in the forward mode and 90.5% in the backup mode), low part count due to its bi-directional feature and galvanic isolation. The results are verified.

2. DESCRIPTION OF BI-DIRECTIONAL DC-DC CONVERTER

Fig.1 shows the power circuit of a bidirectional converter which consists of a half-bridge converter at the primary side of a isolation transformer. In the secondary side, a current-fed push-pull topology is employed. The circuit have a balanced winding NP and two catching diodes

D_1 and D_2 on the primary side of half bridge. They maintain the centre point voltage at the junction of C_1 and C_2 to one half of the input voltage V_s and thus preventing the “RUN AWAY” condition of saturation of the transformer core. For low power applications, the half-bridge is preferred over the full-bridge topology[3-5]. The circuit operation consists of two modes: forward charging mode and reverse discharging mode.

In forward charging mode the energy from the dc mains charges the battery over a specified input voltage range while powering the downstream load converter. In this mode of operation only the switches S_1 and S_2 are gated and the body diodes of the switches S_3 and S_4 provide battery side rectification. In reverse discharging mode the switches S_3 and S_4 are gated and the body diode of the switches S_1 and S_2 provides rectification at the load side. On failure of the dc mains, reversal of power flow occurs. Now, the battery supplies the load power at the dc voltage. In this mode battery discharges the energy, and given to the load hence it is called as reverse discharging mode[6-7].

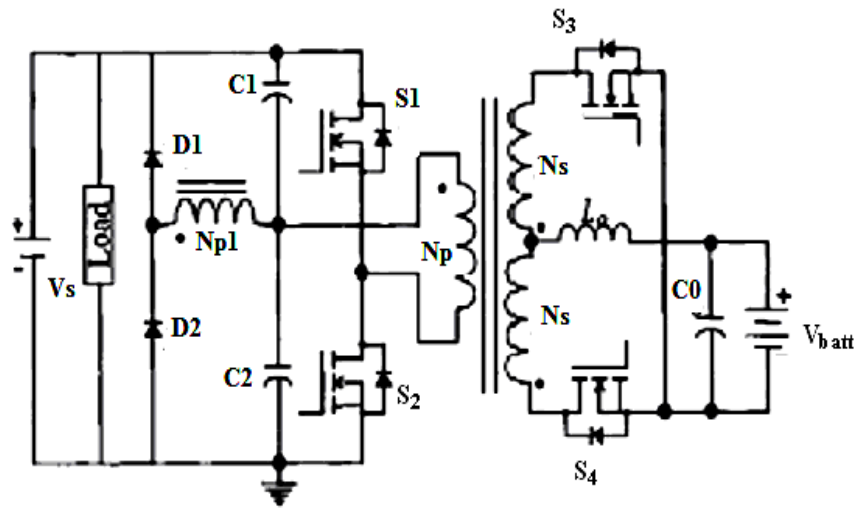

Fig.1.Power circuit of Bi-directional DC-DC Converter

2.1 Forward Charging Mode

In the forward charging mode as shown in Fig.2, main power supply V_s , powering the load converters, provides the battery charging current. This charges the battery of the bi-directional converter at the nominal voltage. The switches S_1 and S_2 on the primary side are gated at duty ratios less than 0.5, while S_3 and S_4 are not switched at all. Operation of the bi-directional converter during this mode is comparable to that of a buck converter. The various stages of operation during one switching time period, T_s , are divided into four intervals t_0 - t_4 [8]. The converter operation is repetitive in the switching cycle.

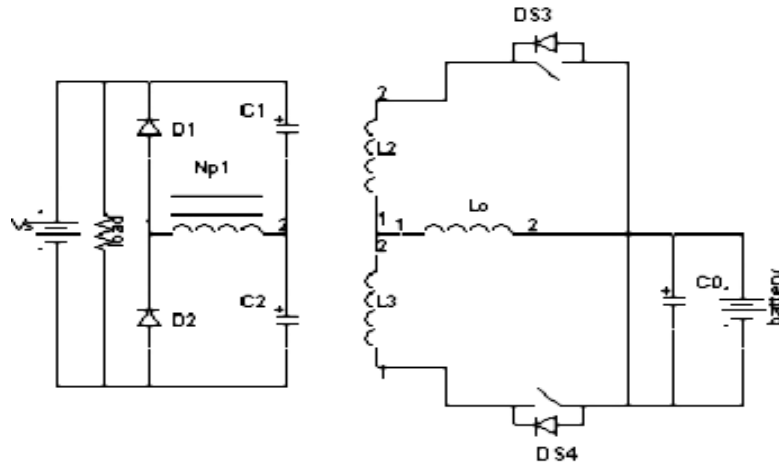

Fig.2.Forward Charging Mode

In the interval, t_0-t_1 , the switch S_1 is turned on by applying the gate pulse at t_0 and the switch S_2 is in the off position. Because of the balancing winding and two catching diodes D_1 and D_2 , the voltage that appears on the primary side of the transformer is $V_s/2$. In the secondary side the diode DS_4 of switch S_4 is forward biased and provides rectification. In this mode the inductor current increases linearly. The primary current, i_{s1} , builds up linearly with increasing inductor current i_{L_0} . In the interval t_1-t_2 , the switch S_1 turned off at t_1 and switch S_2 remains in the off state. In this dead time interval there is no voltage across the primary, and there is zero voltage across the secondary winding and thus there is no power transferred to the secondary side. The stored inductor energy results in the freewheeling of current through the diode DS_3 and DS_4 to charge the battery. Only half of the supply voltage V_s , appears across the switch S_1 and S_2 during this interval.

During the interval t_2-t_3 , S_2 is turned on and S_1 remains in the off state. During this interval voltage appears across the primary winding is $V_s/2$. In the secondary side the diode DS_3 of switch S_3 is forward biased and provides rectification. In this mode the inductor current increases linearly. The primary current, i_{s2} builds up linearly with increasing inductor current i_{L_0} . The battery charging current is carried by the body diode DS_3 . During t_3-t_4 , the switch S_2 turned off at t_3 and switch S_1 remains in the off state. In this dead time interval there is no voltage across the primary, and there is zero voltage across the secondary winding and thus there is no power transferred to the secondary side. The stored inductor energy results in the freewheeling of current through the diode DS_3 and DS_4 to charge the battery. Only half of the supply voltage V_s appears across the switch S_1 and S_2 during this interval.

2.2 Reverse Charging Mode

In this mode the dc supply is not present then the load takes the power from the battery. As shown in Fig.3, the switches S_3 and S_4 are on the secondary side. But the switches S_1 and S_2 are not gated. The various stages of operation during one switching time period can be divided in to intervals are from $t_0 - t_4$.

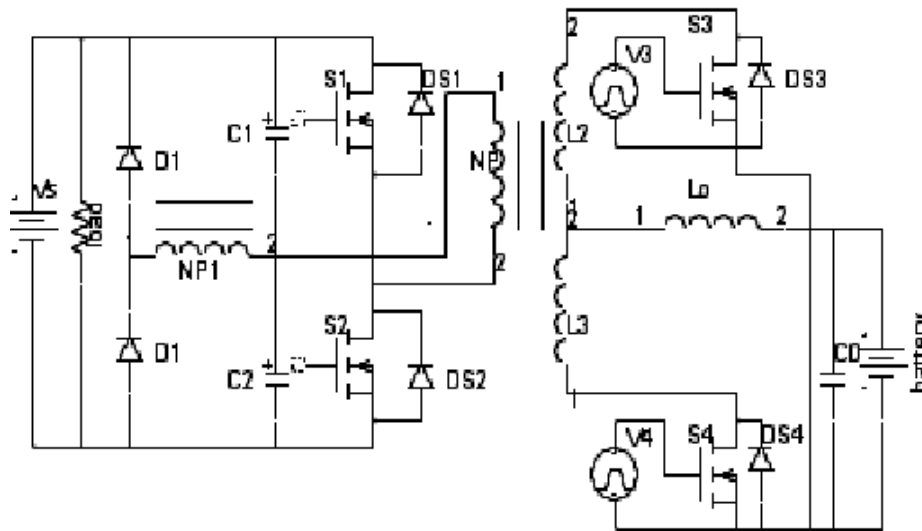

Fig.3.Reverse Discharging Mode

In the interval, t_0-t_1 , the switch S_3 is turned on by applying the gate pulse at t_0 and the switch S_4 remains in the on state. The transformer secondary, N_s , is subject to an effective short circuit, which causes the inductor, L_o , to store energy as the total battery voltage appears across it. The inductor current, i_{L_o} , increase linearly and shared equally by both the switches S_3 and S_4 . During t_1-t_2 , the switch S_4 is turned off at t_1 while S_3 remains in the on state. The energy stored in the inductor, L_o , during the previous interval is now transferred to the load through the body diode DS_2 and the diode D_1 . Voltage across the auxiliary winding NP_1 and the primary winding N_p is identical due to the equal number of turns. This allows simultaneous and equal charging of both C_1 and C_2 through D_1 and DS_2 , respectively.

In t_2-t_3 , the switch S_4 is turned on by applying the gate pulse at t_0 and the switch S_3 remains in the on state. The transformer secondary, N_s , is subject to an effective short circuit, which causes the inductor, L_o , to store energy as the total battery voltage appears across it. The inductor current, i_{L_o} , increase linearly and shared equally by both the switches S_3 and S_4 . During the interval, t_3-t_4 , the switch S_3 is turned off at t_1 while S_4 remains in the on state. The energy stored in the inductor, L_o , during the previous interval is now transferred to the load through the body diode DS_1 and the diode D_2 . Voltage across the auxiliary winding NP_1 and the primary winding N_p is identical due to the equal number of turns. This allows simultaneous and equal charging of both C_1 and C_2 through D_2 and DS_1 .

3. DESIGN EQUATIONS AND SIMULATION RESULTS

The proposed bidirectional DC-DC converter is designed as follows [9]:

The duty ratio is calculated as

$$d_{max} = \frac{V_{battery\ max}}{V_{S\ min}} \quad (1)$$

$$d_{\min} = \frac{V_{\text{battery max}}}{V_{S \text{ max}}} \quad (2)$$

The minimum value of inductance is calculated as follows:

$$L_{\min} = \frac{V_{\text{battery max}} (1 - 2d_{\min})}{4f_s I_{\min}} \quad (3)$$

The output capacitor is calculated as follows:

$$C_o = \frac{L_o I_{\text{battery max}}^2}{V_{\text{battery peak}}^2 - V_{\text{battery ripple}}^2} \quad (4)$$

The value of input capacitors are determined as

$$C_1 = C_2 = \frac{2I_{\text{primary}} t_{\text{discharge}}}{V_{\text{ripple}}} \quad (5)$$

Using the above design equations, the simulation parameters are shown in Table:1

Table:1 Simulation parameters of Bidirectional DC-DC converter

Parameters	Values
Input voltage	380V
Operating frequency	100kHz
Nominal battery voltage	48V
Output power	85W
Duty ratio	0.5
Inductance	360uH
Output Capacitor C _o	470 uF
Input Capacitor C ₁ & C ₂	150uF

Fig.4 shows the voltage across S₁ and S₂ and the voltage is about 380V in the forward charging mode.

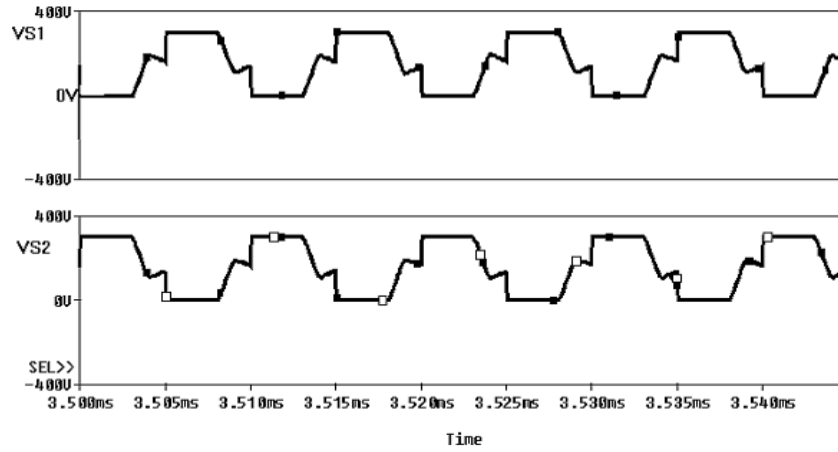

Fig.4.VoltageWaveform across Switch S_1 and S_2

Fig.5 shows the voltage and current through the inductor

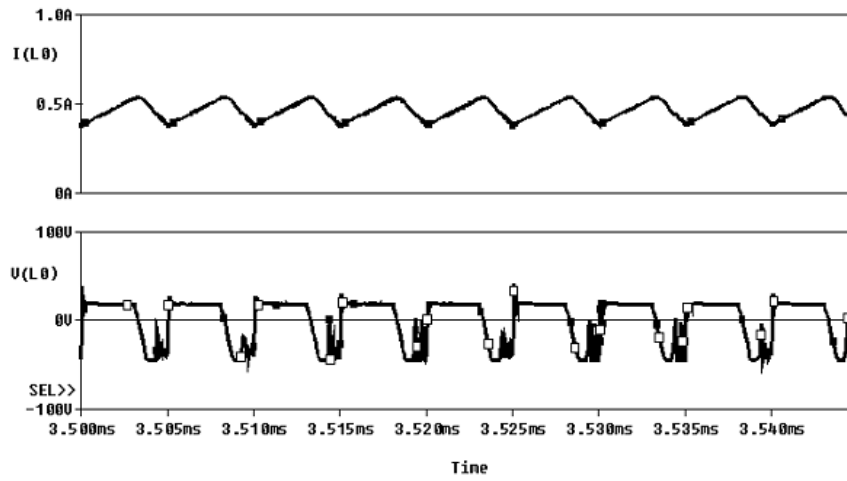

Fig.5.Current through L_0 and voltage across L_0 .

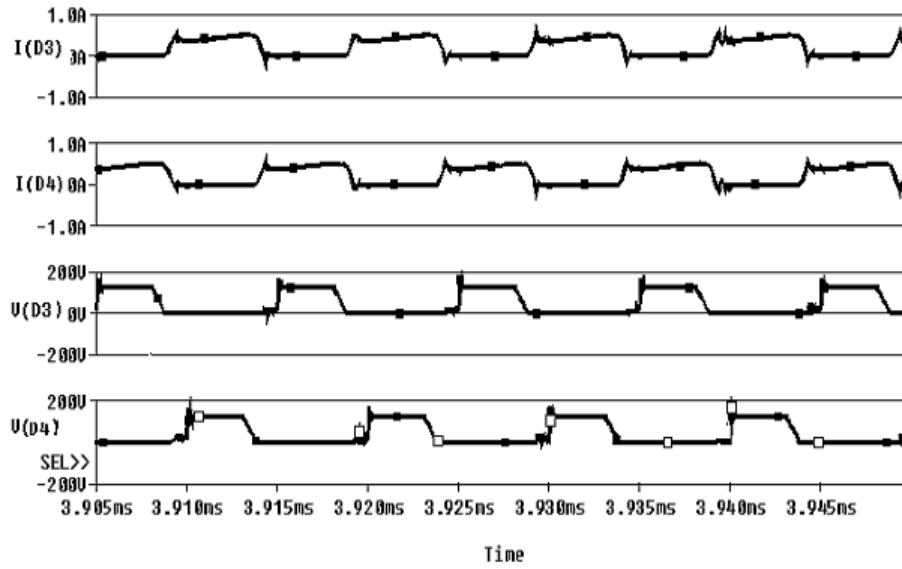

Fig.6.Current through D_{S3} , D_{S4} and Voltage across Switch S_3 , S_4

In the reverse discharging mode, the voltage across S_3 and S_4 is shown in Fig.7.

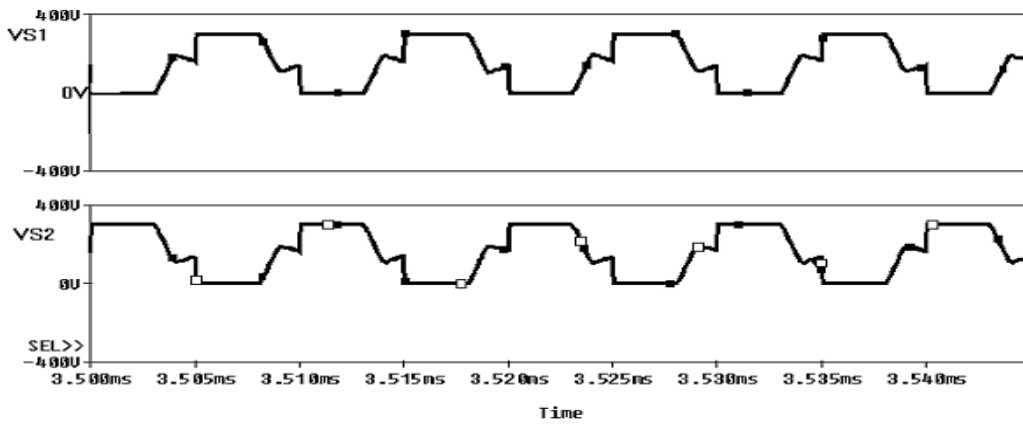

Fig.7.Voltage across switch S_3 and S_4

Fig.8 shows the voltage and current through the inductor

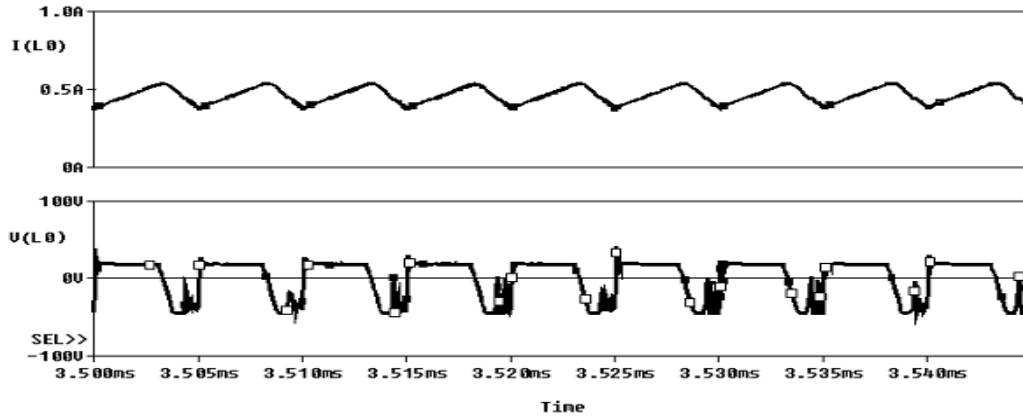

Fig.8. Current through L_0 and voltage across L_0

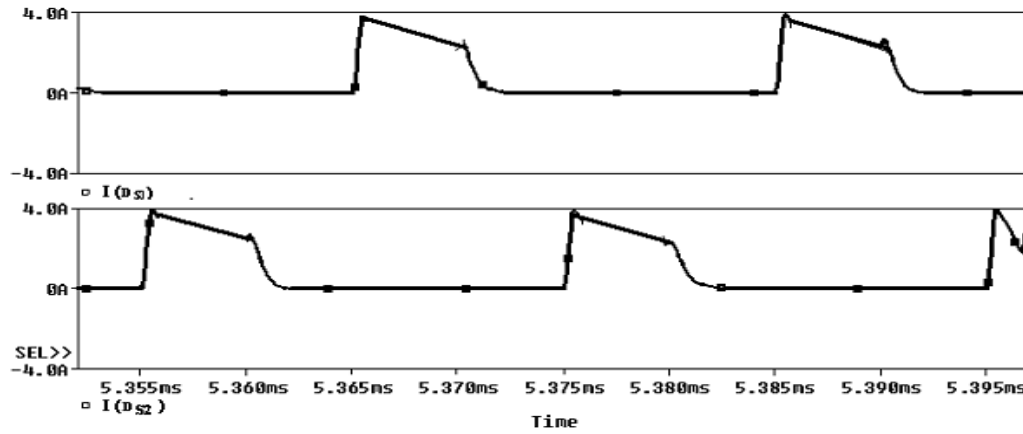

Fig.9. Current through DS_1 and DS_2

Figs.9 & 10 show the current through DS_1 and DS_2 and voltage across S_1 & S_2 .

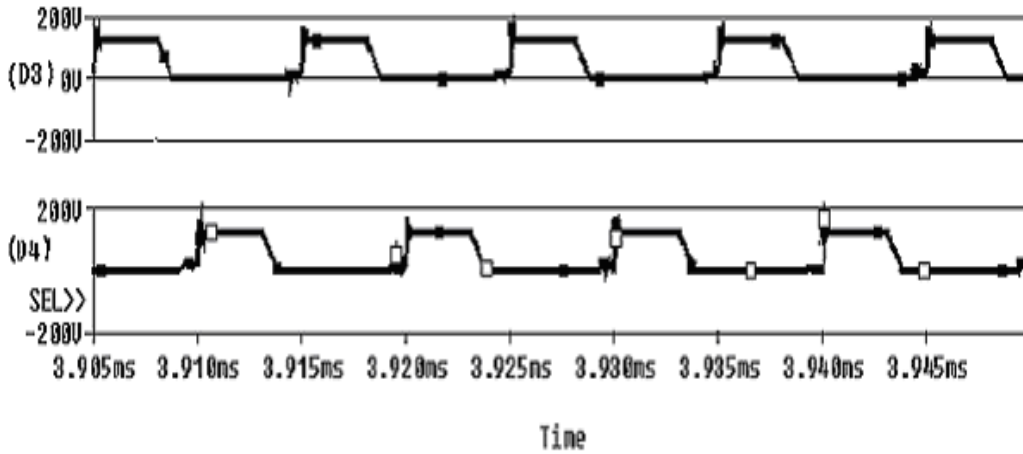

Fig.10. Voltage across switch S_1 and S_2

In order to improve the dynamic response of the converter, a closed loop control is implemented[10]. A compensated error amplifier is added in the feedback path. This amplifier reduces the steady-state error and the compensation circuit is shown in Fig.11.

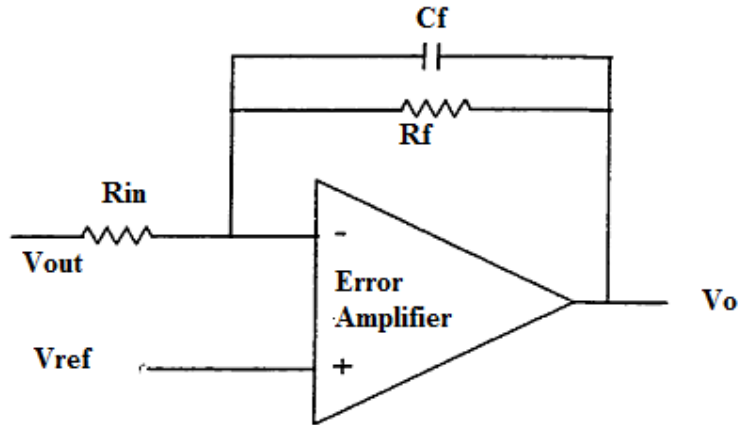

Fig.11 Compensation circuit for the error amplifier

The values of the feedback elements are properly chosen so that the dynamic response of the converter is faster. Fig.12 shows the voltage across the load without disturbance in open loop condition under forward charging mode.

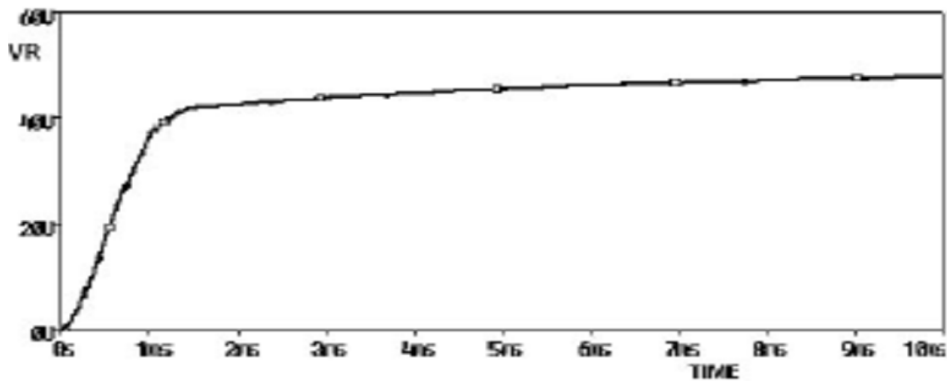

Fig.12 Voltage across load without disturbance in open loop condition

At $t = 4\text{ms}$, a disturbance is provided and the voltage across the load is shown in Fig.13. Fig.14 shows the output voltage of op-amp.

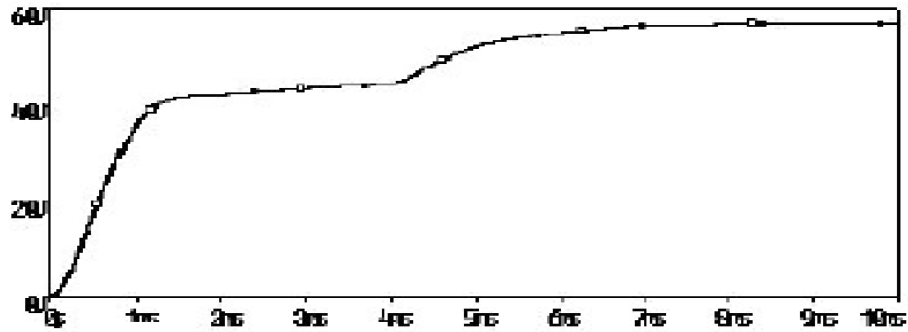

Fig.13.Voltage across the load with disturbance provided at 4ms

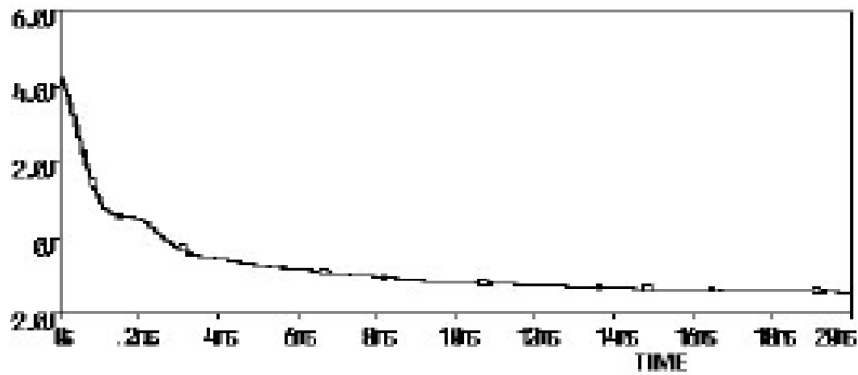

Fig.14.Output voltage of Op-amp

In the reverse charging mode, the voltage across the load in open loop condition is shown in Fig.15.

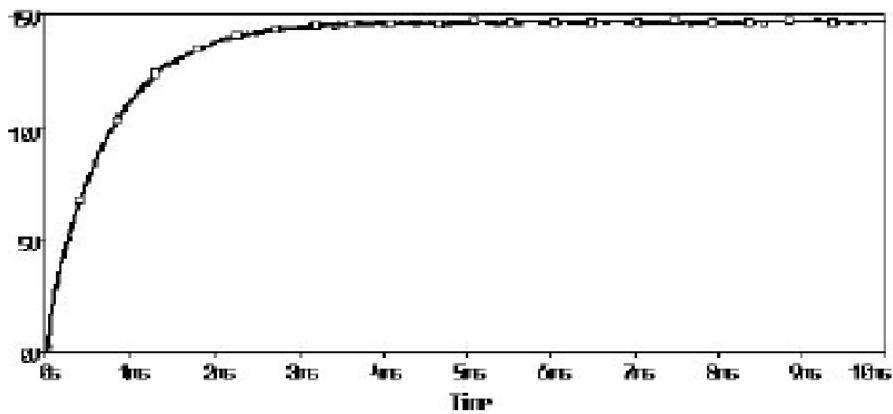

Fig.15.Voltage across load without disturbance in open loop condition

At $t = 4\text{ms}$, a disturbance is provided and the voltage across the load is shown in Fig.16.Figs.17 & 18 shows the output voltage of op-amp and proportional controller.

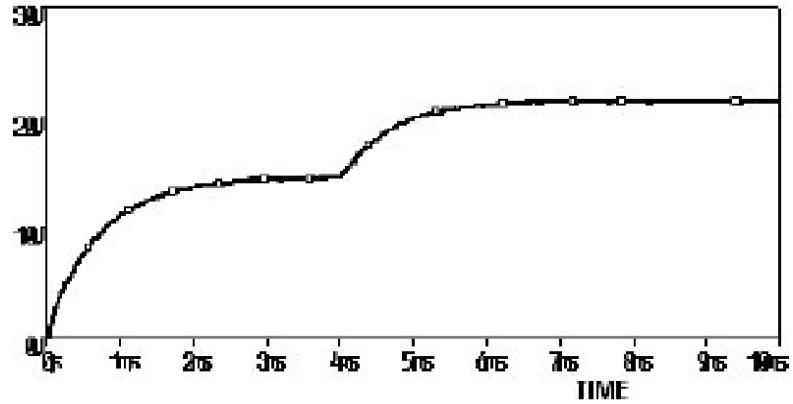

Fig.16.Voltage Across Load With Disturbance TD=4ms

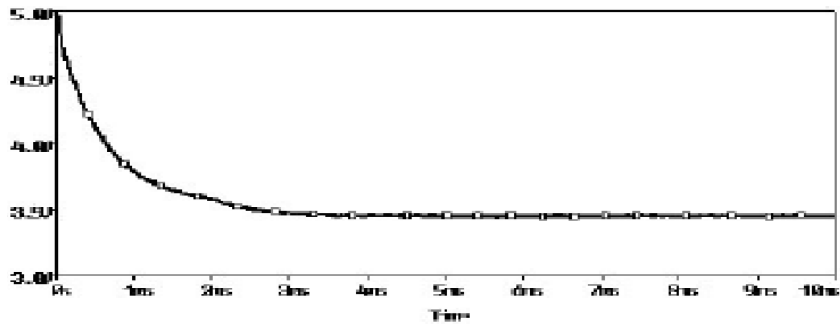

Fig.17.OPAMP output voltage

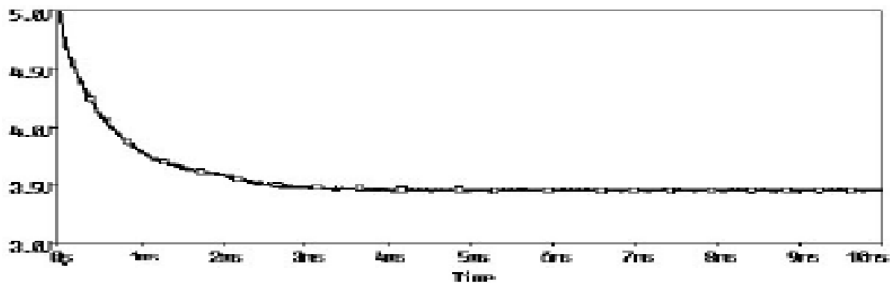

Fig.18. Output voltage across proportional voltage controller

With closed loop control, the output voltage of the bidirectional converter is controlled both in the forward and reverse charging modes.

4. CONCLUSION

A bi-directional DC-DC converter in forward and reverse charging modes have been presented in this paper. Moreover, to improve the dynamic response of the converter, a feedback system is also employed and the output voltage is regulated. Therefore, the proposed converter will be a suitable topology for PV applications.

REFERENCES

- [1] H. G. Langer and H. -Ch. Skudelny (1989), "DC to DC converters with bi-directional power flow and controllable voltage ratio," in Proc. IEE EPE Conf., pp. 1245–1250.
- [2] Capel (1986), "A bidirectional high power cell using large signal feedback control with maximum current control for space applications," in Proc. IEEE Power Electron. Spec. Conf., pp. 684–695.
- [3] K. Venkatesan (1989), "Current mode controlled bidirectional fly back converter," in Proc. IEEE Power Electron. Spec. Conf, pp. 835–842.
- [4] Ray (1992), "Bidirectional dc–dc power conversion using quasiresonant topology," in Proc. IEEE Power Electron. Spec. Conf., pp. 617–624.
- [5] Inoue, S. & Akagi, H. (2007). A Bidirectional DC-DC converter for an Energy storage system With Galvanic Isolation. IEEE Transactions on Power Electronics, Vol. 22, No. 6, (2007), pp. 2299-2306, ISSN 0885-8993.
- [6] Krismer, F., Biela J. & Kolar, J.W. (2005). A comparative evaluation of isolated bi-directional DC/DC converters with wide input and output voltage range, Proceedings of the Fourtieth IAS Annual Meeting, Vol.1, pp. 599-606.
- [7] Yu, W., Qian, H. and Lai, J.S. (2010), "Design of High-Efficiency Bidirectional DC–DC Converter and High-Precision Efficiency Measurement", IEEE Transactions on Power Electronics, Vol. 25, No. 3,, pp. 650-658.
- [8] Tao, T., Duarte, J.L. & Hendrix, M.A.M. (2008). Three-Port Triple-Half-Bridge Bidirectional Converter With Zero-Voltage Switching. IEEE Transactions on Power Electronics, Vol. 23, No. 2, pp. 782-792.
- [9] Yu, W., Qian, H. & Lai, J.S. (2010). Design of High-Efficiency Bidirectional DC–DC Converter and High-Precision Efficiency Measurement. IEEE Transactions on Power Electronics, Vol. 25, No. 3, (March 2010), pp. 650-658, ISSN 0885-8993.
- [10] Sheng-Yuan Ou , Ho-Pu Hsiao and ChenHung Tien (2010), "Analysis and Design of a Prototype Single-Stage Half-Bridge Power Converter,"2010 5th IEEE Conference on Industrial Electronics and Applications, pp.1168-1173.